

# Motor Protection Circuit Breakers

## 3VU13 and 3VU16

3VU13/3VU16 is suitable for use in fuseless motor feeders upto 11KW/22KW (25A/63A) respectively. 3VU motor protection circuit breakers are used for protection of motor against overload, single phasing and short-circuit faults.

### Applications

- **Motor Protection**

Circuit breakers type 3VU13 & 3VU16 offer overload, short circuit and phase loss protection for 3 phase motors upto 11kW and 22 kW respectively. The breaker has a toggle switch for ease of operation and can be offered with auxiliary contacts, trip indicating contacts, U/V or Shunt release. High breaking capacity of 100kA is available in 3VU13 upto 6A and in 3VU16 upto 25A.

- **Distribution Feeder Protection**

Standard version of 3VU13 and 3VU16 has adjustable O/L and fixed S/C release. Main application is for disconnection and protection of the distribution feeders, upto 25A and 63A respectively. A large number of overlapping ranges are available for offering closer protection to various loads.

- **Transformer protection**

A separate 3VU13 range can be offered to protect the primary side of the transformers. The range is available upto 20A. To take care of the inrush current due to transformer switching, the S/C release is set at 19 times the rated current unlike 12 times of the rated current available in standard range.

- **Fuse Monitoring**

3VU1340-1MS00 is offered for Fuse Monitoring application. This device is connected in parallel to the fuses. In case one of the fuses blows, the rated current will flow through the corresponding phase of this MPCB. MPCB, through its auxiliary contacts, provides a tripping signal to the contactor and thus the motor will be switched off. Hence, the motor will be protected from single phasing. (Refer page 51 for connection diagram)



3VU13/16

### Standard

3VU motor protection circuit breakers confirm to IS/IEC 60947-1, IS/IEC 60947-2, IS/IEC 60947-4-1, DIN VDE 0660

### Range

3VU13: 0.16 - 25A

3VU16: 10 - 63A

### Benefits and features

#### High performance

- **Instantaneous Tripping**

3VU circuit breakers operate on the **Current Limiting Principle**.

#### Current Limiting Principle

In case of short-circuit condition motor protection circuit breaker trips before the short-circuit current reaches the prospective peak. Hence, for circuit breaker to be current limiting it must interrupt the short-circuit current in half cycle or less as shown below.

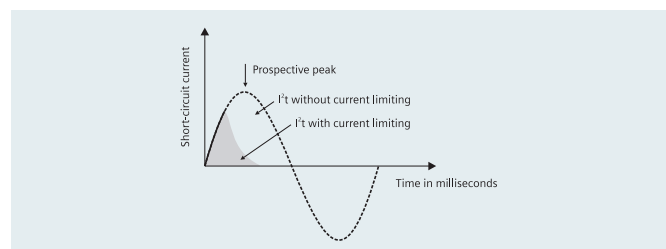

Fuse Monitoring MPCB - 3VU1340-1MS00

**Current Limiting is achieved in 3VU as follows**

In case of a short circuit, the contacts are opened electro-dynamically by the short circuit current. The instantaneous overcurrent release, through the switching mechanism, trips all the three poles of the breaker. A large arc voltage is quickly built up in the arc chamber limiting the short circuit current. Thus ensures faster fault clearing.

- Ambient temperature compensation upto 55°C hence no deration required upto 55°C.

**Safety**

- **Trip Free Mechanism**  
The breakers have a trip-free mechanism. Even by holding the toggle, tripping operation can not be stopped or blocked once it is started. Thus ensure positive opening in the event of fault.
- **Positive ON/OFF indication through toggle switch**
- **Compact and space saving**

**User friendliness and safety**

- SIGUT® connection technique ensures ease of wiring (can obviate use of lug)
- Fingers touch proof terminals ensures operator safety
- Separate trip indication on short circuit and overload fault using alarm contact

**Flexibility**

- Can be used as a main and EMERGENCY STOP switch.
- Identical accessories reduce stock levels

**Selection and ordering data**

**3VU13 Circuit - breakers with 1NO+1NC auxiliary contacts for motor and plant protection**

Rated Current In A	Overload release range A	Shortcircuit release setting A	Type <sup>§</sup>	Recommended 415V Motor Rating in Kw/HP (DOL)	Std. pkg. (nos.)
0.16	0.1 - 0.16	1.9	3VU1340-1MB00	–	1
0.24	0.16 - 0.24	2.9	3VU1340-1MC00	–	
0.4	0.24-0.4	4.8	3VU1340-1MD00	–	
0.6	0.4-0.6	7.2	3VU1340-1ME00	–	
1	0.6-1	12	3VU1340-1MF00	0.25/0.33	
1.6	1-1.6	19	3VU1340-1MG00	0.37/0.5	
2.4	1.6-2.4	29	3VU1340-1MH00	0.75/1	
3.2	2-3.2	38	3VU1340-1NH00	1.1/1.5	
4	2.4-4	48	3VU1340-1MJ00	1.5/2	
5	3.2-5	60	3VU1340-1NJ00	2.2/3	
6	4-6	72	3VU1340-1MK00	3/4	
8	5-8	96	3VU1340-1NK00	3.7/5	
10	6-10	120	3VU1340-1ML00	4/5.4	
13	8-13	156	3VU1340-1NL00	5.5/7.5	
16	10-16	190	3VU1340-1MM00	7.5/10	
20	14-20	240	3VU1340-1MN00	9.3/12.5	
25	18-25	300	3VU1340-1MP00	11/15	

**3VU13 Circuit - breakers with 1NO+1NC auxiliary contacts for line-side protection of transformers with high inrush current**

Rated Current In A	Overload release range A	Shortcircuit release setting A	Type	Std. pkg. (nos.)
0.6	0.4-0.6	12	3VU1340-1TE00	1
1	0.6-1	15	3VU1340-1TF00	
1.6	1-1.6	29	3VU1340-1TG00	
2.4	1.6-2.4	48	3VU1340-1TH00	
4	2.4-4	72	3VU1340-1TJ00	
6	4-6	120	3VU1340-1TK00	
10	6-10	190	3VU1340-1TL00	
16	10-16	300	3VU1340-1TM00	
20	14-20	300	3VU1340-1TN00	

**Fuse monitoring motor protection circuit - breakers with 1NO+1NC auxiliary contacts**

Rated Current In A	Overload release range A	Shortcircuit release setting A	Type	Std. pkg. (nos.)
0.2	0.2	1.2	3VU1340-1MS00	1

**3VU16 Circuit - breakers with 1NO+1NC auxiliary contacts for motor and plant protection**

Rated Current In A	Overload release range A	Shortcircuit release setting A	Type <sup>§</sup>	Recommended 415V Motor Rating in Kw/HP (DOL)	Std. pkg. (nos.)
10	6-10	120	3VU1640-1ML00	4/5.4	1
16	10-16	190	3VU1640-1MM00	7.5/10	
25	16-25	300	3VU1640-1MN00	11/15	
32	22-32	380	3VU1640-1MP00	15/20	
40	28-40	480	3VU1640-1MQ00	18.5/25	
52	36-52	600	3VU1640-1MR00	22/30	

**3VU16 Circuit - breakers for plant protection**

Rated Current In A	Overload release range A	Shortcircuit release setting A	Type <sup>§</sup>	Std. pkg. (nos.)
63	45-63	600	3VU1640-1LS00	1

<sup>§</sup> The 3VU13 and 3VU16 circuit breakers are also available without auxiliary contacts. To order the same, the 8th place of the type number is to be replaced with the digit 0.

## Technical Data

According to DIN VDE 0660; IS/IEC 60947-1; IS/IEC 60947-2; IS/IEC 60947-4-1

Type		3VU13		3VU16	
Number of poles		3		3	
Max. rated current $I_n$					
• motor protection	A	25		52	
• distribution	A	25		63	
Permissible ambient temperature					
• at full rated current	°C	-20 ... +55			
• in storage	°C	-50 ... +80			
Rated operational voltage $U_e$	V	690			
Rated frequency	Hz	50/60			
Rated insulation voltage $U_i$	V	750			
Rated impulse withstand voltage $U_{imp}$	kV	6			
Utilization category					
• to IS/IEC 60947-2 (motor starter protection)		A			
• to IS/IEC 60947-4-1 (motor starters)		AC-3			
Mechanical endurance	Operating cycles				
• up to 25 A	1/h	100,000		100,000	
• 25 A upwards	1/h	–		30,000	
Number of operating cycles/h (on load)	1/h	25		25	
Degree of protection with open terminals/with conductors connected		IP00/IP20			
Temperature compensation	to IS/IEC 60947-4-1	Yes			
Phase failure sensitivity	to IS/IEC 60947-4-1	Yes			
<b>Auxiliary contact for 3VU13 and 3VU16</b>					
Rated operational voltage $U_e$	AC V	230	400	500	
Rated operational current $I_e$	A	3	1.5	1.2	
Utilization category		AC-15			
Rated operational voltage $U_e$ DC L/R 200 ms	DC V	24	60	220	
Rated operational current $I_e$	A	2.3	0.7	0.3	
Utilization category		DC-13			
<b>Wattloss Per Breaker</b>					
		<b>Current rating</b>	<b>Watt</b>	<b>Current rating</b>	<b>Watt</b>
		0.6	5	2.4	8
		4	6	6	7
		6	7	25	14
		25	9	63	23
<b>Cross-section for main conductors</b>					
Solid or stranded	mm <sup>2</sup>	2 x (1 ... 6)		1 x 1.5 ... 2 x 16 or 1 x 25 + 1 x 10	
Finely stranded with end sleeve	mm <sup>2</sup>	2 x (1 ... 4)		1 x 1.5 ... 2 x 10 or 1 x 16 + 1 x 10	
<b>Cross-sections for auxiliary and control connecting leads</b>					
Solid or stranded	mm <sup>2</sup>	1 x 0.5 ... 2 x 2.5			
Finely stranded with end sleeve	mm <sup>2</sup>	1 x 0.5 ... 2 x 2.5			

## Technical data for accessories:

		3VU13	3VU16
<b>Undervoltage Release</b>			
Consumption During Pick-up	VA/W	10/6	
Consumption During Running	VA/W	4.7/2	
Dropout	V	0.7 to 0.35 X Ue	
Pickup	V	85 to 110% of Ue	
Max Operating Time	ms	20	
<b>Shunt Release</b>			
Consumption	VA/W	10/6	
Max Continuous Rating	Sec	5	
Pickup	V	0.7 to 1.1 X Ue	
<b>Current Limiter for 3VU13</b>			
Rated current In		56 Amps	
Rated Voltage Ue		500 V, 50 / 60 Hz.	
Power Connection	mm <sup>2</sup>	2 x (1 to 6)	
<b>Mounting</b>			
		on DIN Rail in any position.	

**Table 1 3VU13/3VU16 breaking capacity at 415V**

### 3VU13

Rated current A	0.16-1	1.6	2.4	3.2-4	5-6	8-10	13-16	20-25
Rated Short circuit breaking capacity @ 415V								
Icu kA	100	100	100	100	100	10(50)	6(50)	6(50)
Ics kA	100	100	100	100	100	10(50)	6(50)	6(50)
<b>Maximun back up fuse (gL/gG)</b>								
Diazed A	*	*	*	*	*	80	80	80
NH A	*	*	*	*	*	80	80	80
( ) Values in bracket are with current limiter; * Fuse not required								
For 3VU13 breakers of ratings 8A & above, in place of fuses, the Current Limiter can be used to increase the S/C breaking capacity.								
<b>Rated Breaking Capacity DC; t = 15ms</b>								
1 Contact	2 Contacts in series	3 Contacts in series	<b>10 kA</b>					
110-150V	220-300V	330-450V						

### 3VU16

Rated current A	1.6-2.4	4	6	10	16	25	32-63
Rated Short circuit breaking capacity @ 415V							
Icu kA	100	100	100	100	100	100	35
Ics kA	100	100	100	100	100	50	17
<b>Maximun back up fuse (gL/gG); * Fuse not required</b>							
Diazed A	*	*	*	*	*	*	-
NH A	*	*	*	*	*	*	200
<b>Rated Breaking Capacity DC; t = 15ms, upon enquiry</b>							

# Characteristic Curves

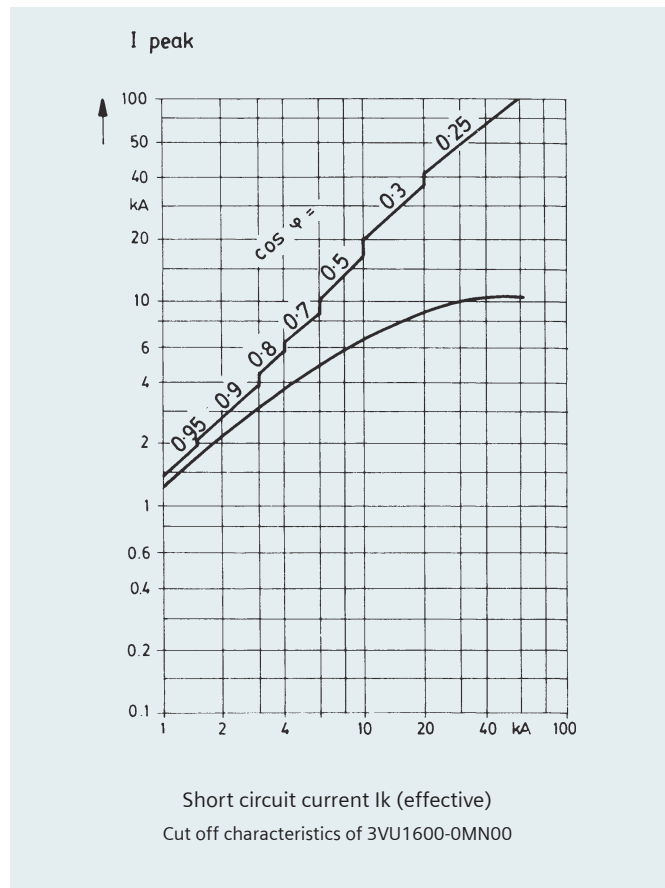
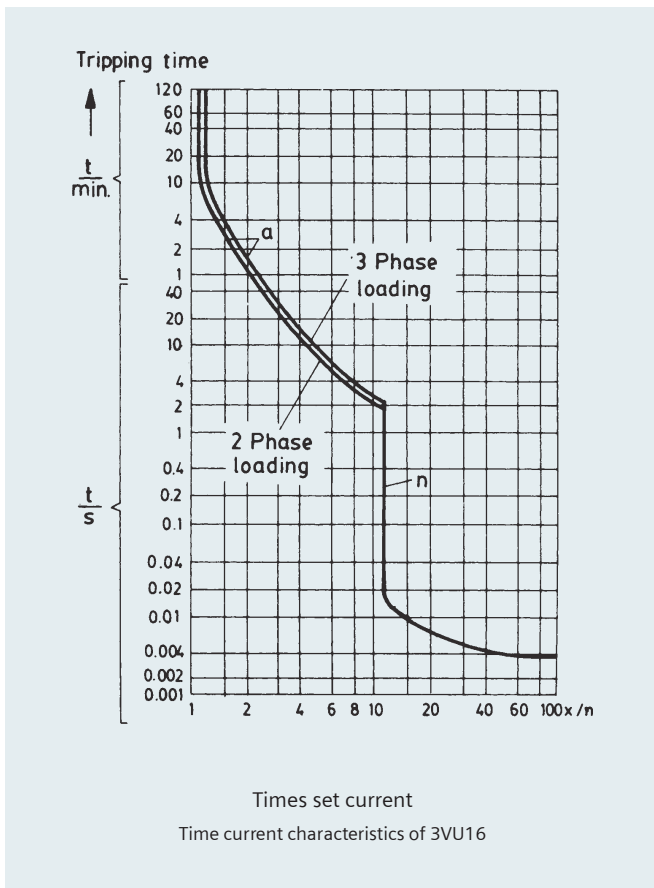
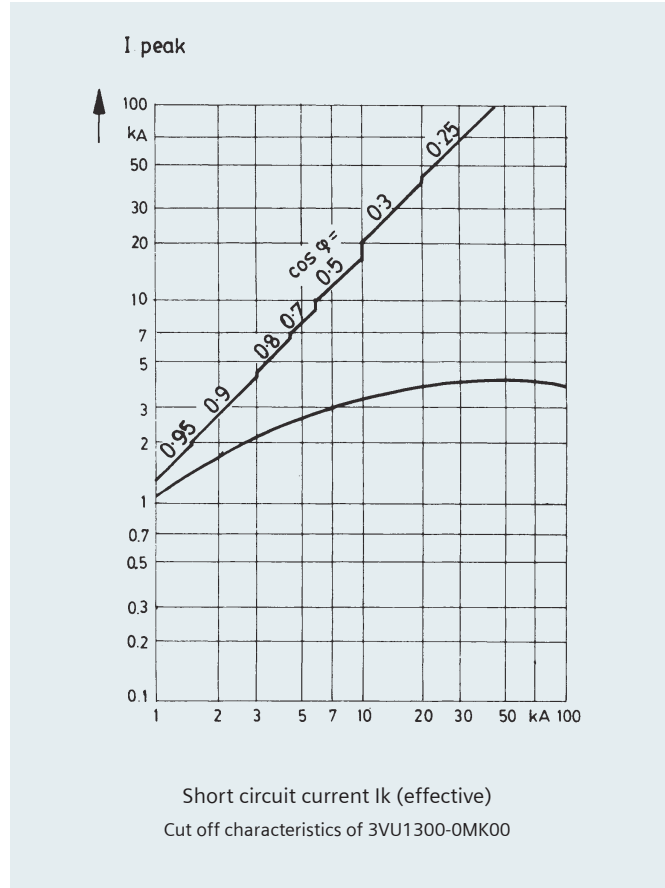
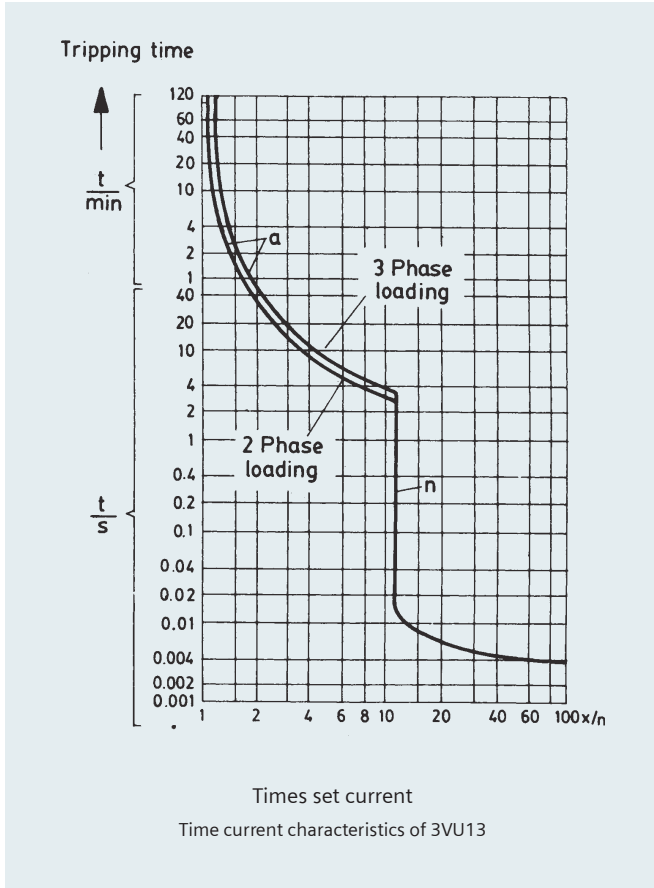

Accessories:

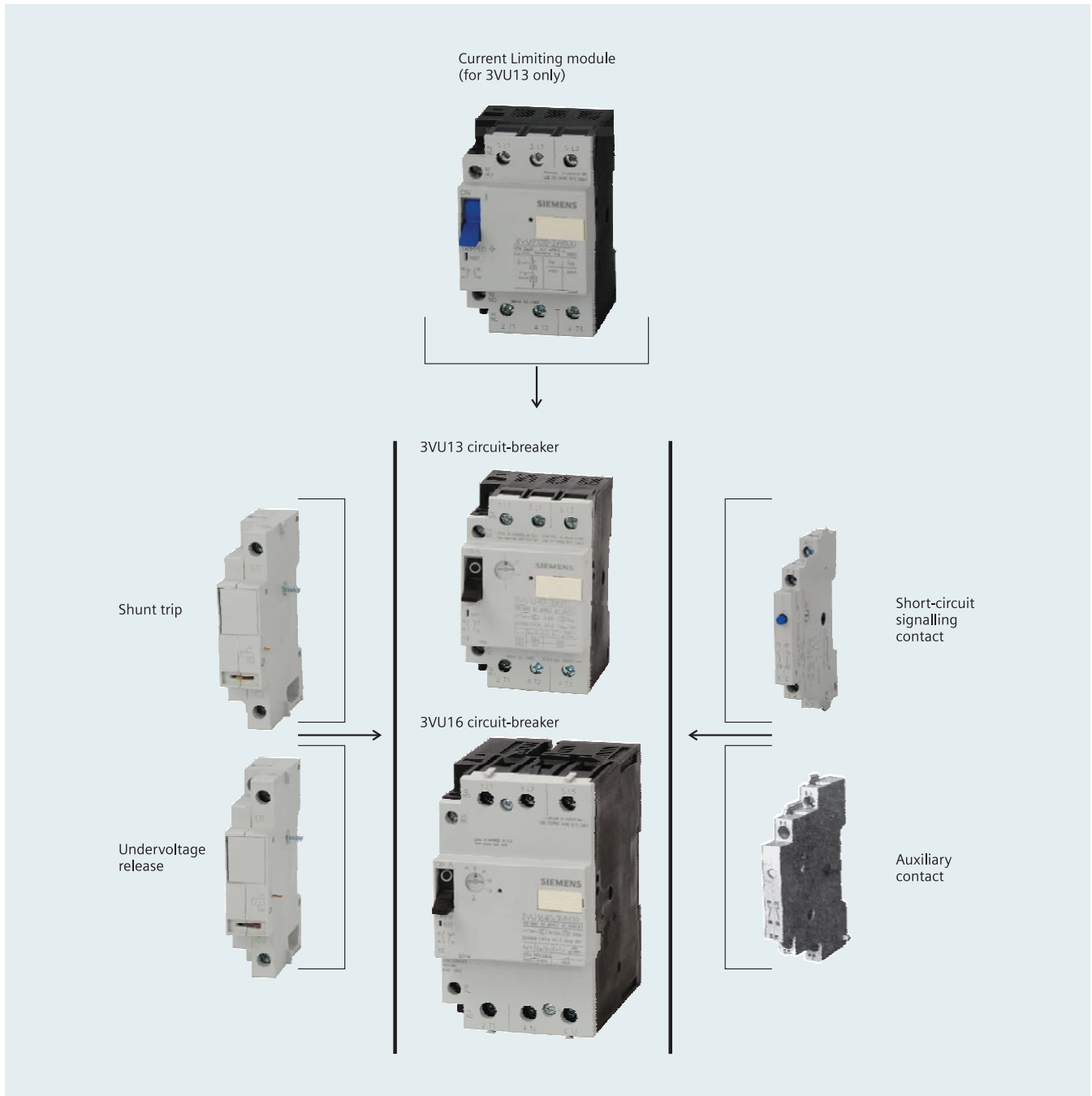

RHS	Alarm contact (1NO + 1NC)	When short circuit (and not overload) occurs, alarm contact 1NO+1NC changes over which can be used to give indication. We need to reset it manually after clearing of short circuit. It performs a function of reclosing lockout.
		and/or
	Auxiliary Contact (1NO + 1NC)	This contact can be added to the MPCB with or without built -in 1NO+1NC contact.
LHS	Shunt Release	Shunt trip is used for remotely tripping the MPCB.
		or
	Undervoltage Release	It trips the MPCB on voltage interruption, preventing the undesirable restart of the motor.
<b>On Top (applicable to 3VU13 only)</b>	Current Limiting Module (independent mounting)	For increasing breaking capacity of 3VU13 to 50kA for 8 - 25A

## Current-Limiter



The breaking capacity of 3VU13 is 100kA upto 6A. However for 3VU circuit breakers with rated current of 8A and 10A the short-circuit breaking capacity is 10kA. For circuit breakers with rated current from 16A to 25A the short-circuit breaking capacity is 6kA. In order to enhance the breaking capacity to 50kA, for these ratings (8A to 25A), the current limiter can be used. Thus the need of back up fuses is obviated.

The current limiter is connected in series with 3VU13 MPCB.

When a short circuit occurs, the limiter trips and in turn opens the downstream MPCB. The auxiliary contacts of the current limiter (1NO+1NC) can be used for signaling whether the limiter has tripped or not.

Several MPCBs can also be connected at the output of a current limiter. However the summation of current ratings of individual MPCBs should not be greater than 56A.

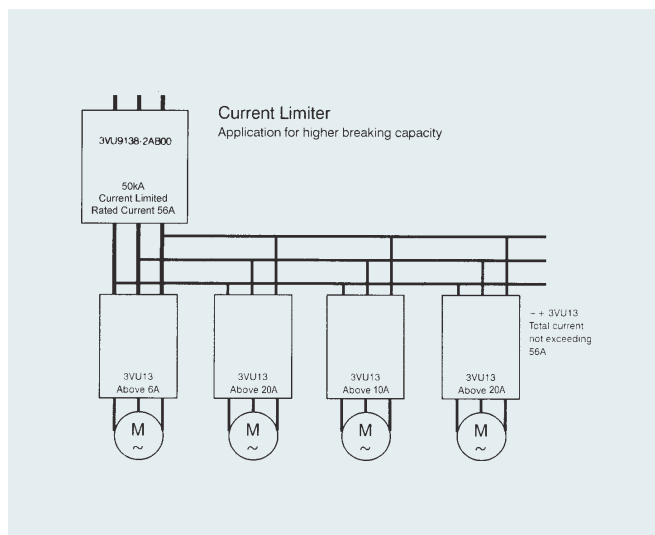

## Connection diagrams

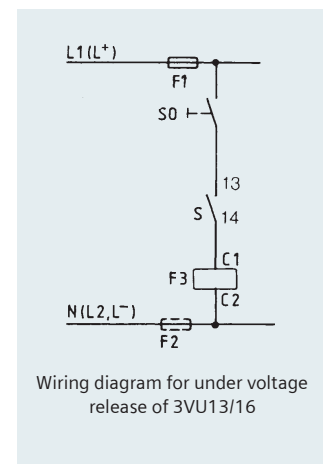
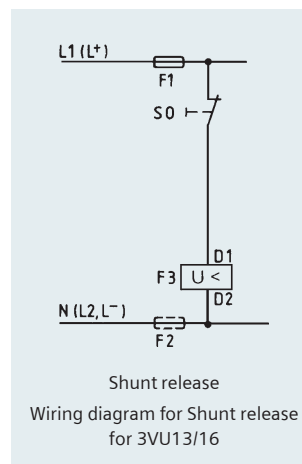
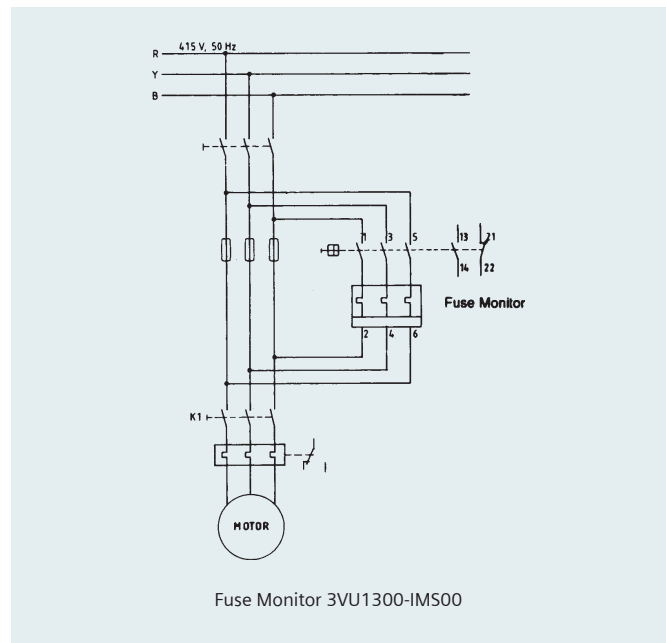
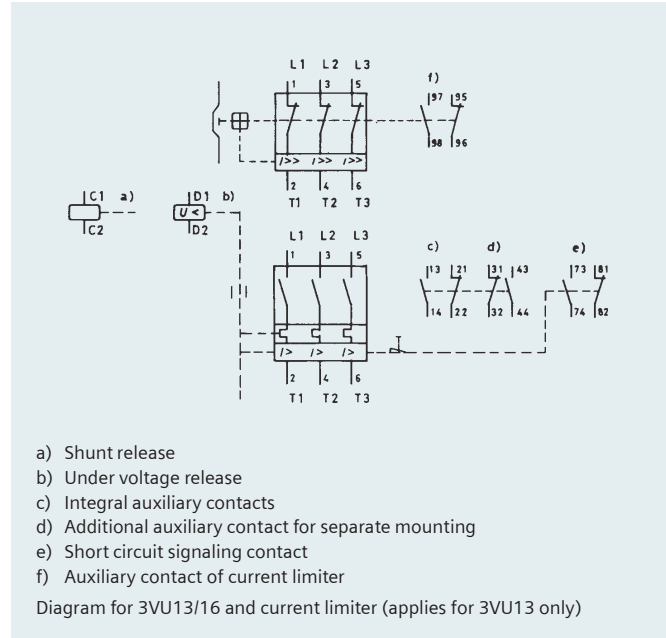

## Accessories and ordering data



3VU9131-3AA0  
Add on Auxiliary block  
1NO + NC



3VU9131-7AA00  
S/C Trip indicating contacts  
1NO + 1NC



3VU9132-0AB15  
220/230V 50Hz  
Under Voltage release



- 3VU9132-0AB55, 220/230V 50Hz
- 3VU9132-0AB50, 24V/50Hz
- 3VU9132-0AB73, DC 110-240V

Shunt release

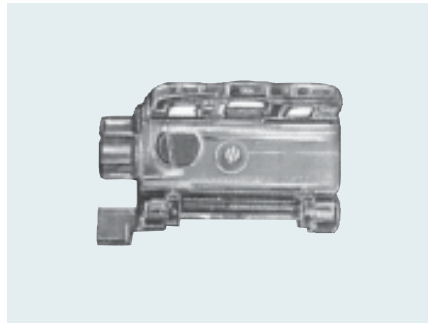

3VU9168-0KA00  
Padlocking for Toggle  
Handle 3VU13/16

### 3 Ø Insulated Bus-bar System for 3VU13

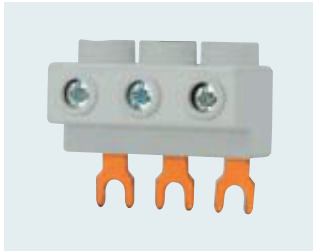

3RV19 25-5AB  
3 Ø feed-in Terminal, max rating  
63A, for bus-bar system



3VU9135-1AB02  
3 Ø Busbars for 2 Breakers  
Max. 63Amps

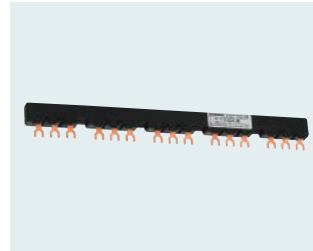

3VU9135-1AB05  
3 Ø Busbar for 5 Breakers  
Max 63 Amps

Also available

- 3VU9135-1AB03  
3 Ø Busbar for 3 breakers
- 3VU9135-1AB04  
3 Ø Busbar for 4 Breakers

### Door operating mechanism for 3VU13/16\*

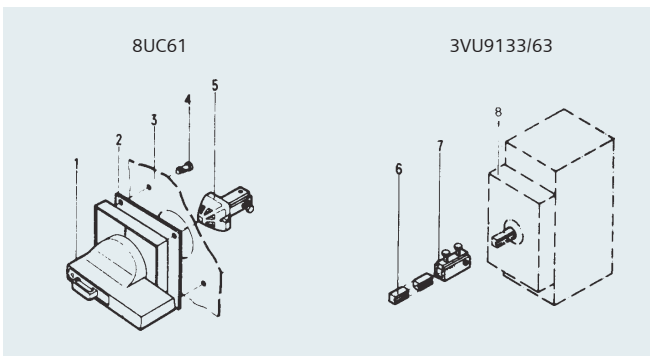

1. Handle with masking frame
2. Gasket
3. Door
4. Fixing screws
5. Drive coupling
6. Extension shaft - 300 mm
7. Adapter
8. Breaker operator

Breaker Operator Kit for 3VU13 - 3VU9133  
Breaker Operator Kit for 3VU16 - 3VU9163

\* For complete assembly, please order both front drive and breaker operator kit.

Note: All the above accessories have standard package no. = 1



## Dimensional Drawings

### 3VU13 circuit-breakers and accessories

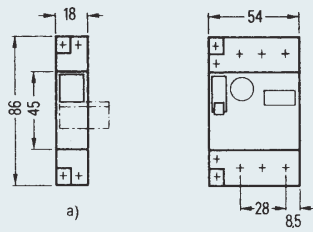

#### 3VU13 circuit-breakers

can be combined with

- a) undervoltage or shunt release and/or
- b) short-circuit signalling switch and/or
- c) auxiliary contacts

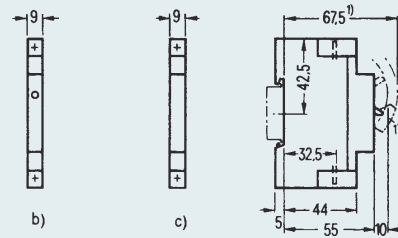

#### 3VU9 138-2AB00 limiter

The limiter has the same dimensions as the standard version of the 3VU13 circuit-breaker

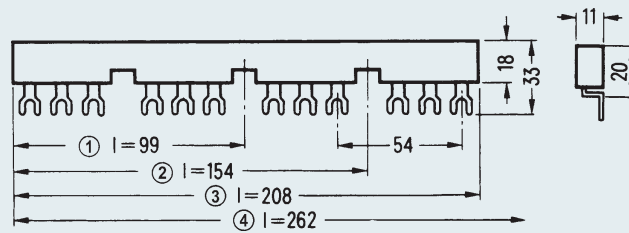

3VU9 135-1AB02, 3VU9 135-1AB03,  
3VU9 135-1AB04, 3VU9 135-1AB05  
three-phase busbar

- ① For 2 devices: 3VU9 135-1AB02
- ② For 3 devices: 3VU9 135-1AB03
- ③ For 4 devices: 3VU9 135-1AB04
- ④ For 5 devices: 3VU9 135-1AB05

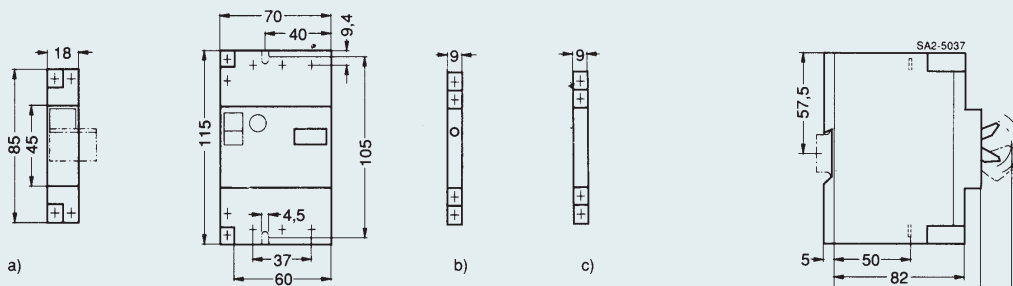

#### 3VU16 circuit-breakers

can be combined with

- a) undervoltage or shunt release and/or
- b) short-circuit signalling switch and/or
- c) auxiliary contacts

Door operating mechanism with extension shaft (300mm) with door interlock & padlocking facilities.

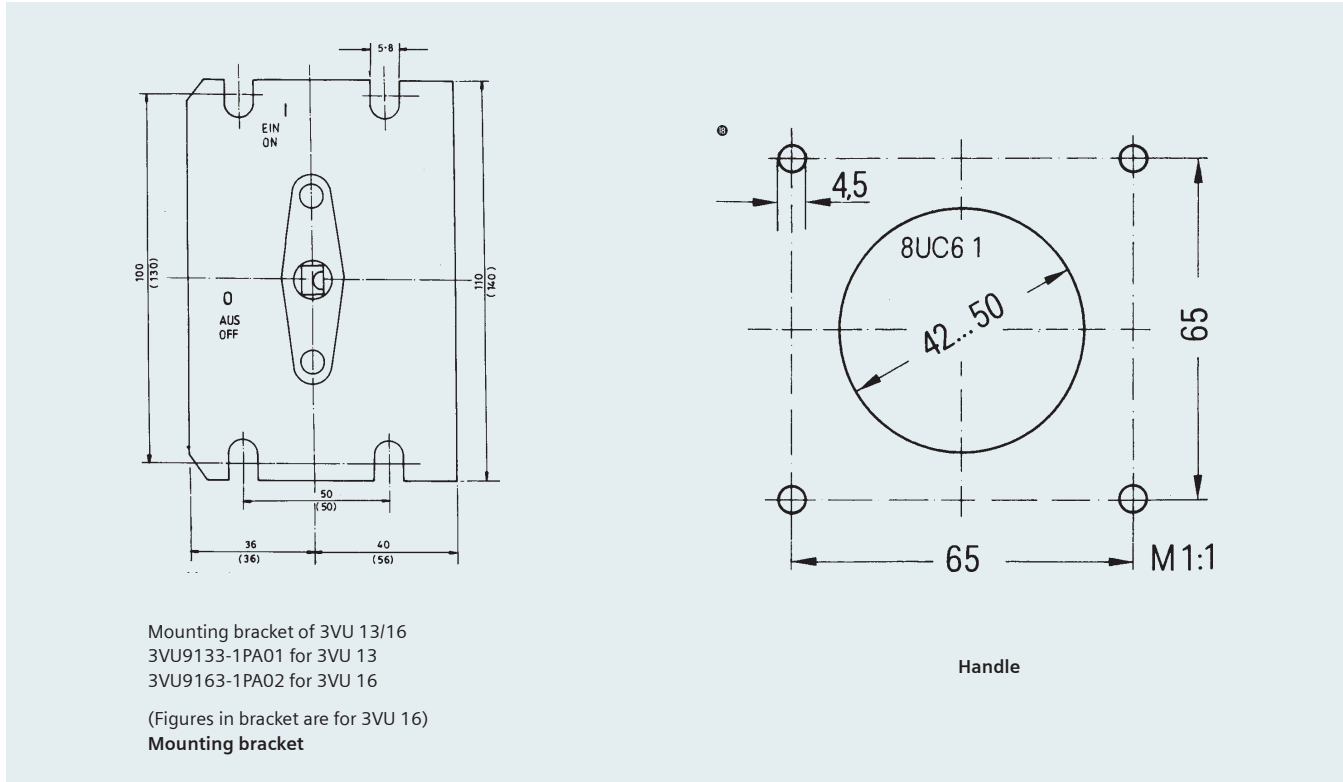

**Required space above arc chutes for 3VU13 and 3VU16**

Minimum clearance to adjacent parts as well as non-insulated live parts.

